



Donaldson
FILTRATION SOLUTIONS

Process Filtration From Pure to Sterile

P-EG

MAIN FEATURES & BENEFITS:

- High quality stainless steel design
- Extremely low differential pressure
- Various connection types
- From 60 m³/h up to 23.000 m³/h



INDUSTRIES:



- Food & Beverage



- Engineering



- Chemical Industry



- Pharmaceutical Industry



- Automotive

Donaldson Filtration Deutschland GmbH
Büssingstr. 1
42781 Haan
Germany

Web: www.donaldson.com

Donaldson[®]
Ultrafilter

PRODUCT DESCRIPTION

P-EG filter housings have been developed for the purification of compressed air and other technical gases in industrial ranges of application. Due to the optimized construction they offer low differential pressure at high flow rates. Numerous different sizes of housings with various connections make it possible to adopt the filter system to exactly the needed requirements.

This product series contains 18 different sizes of housings for operating volume flows of 60 to 23.040 Nm³/h related to 7 bar(g). The Donaldson plug connection guarantees that the elements remain safely fixed at all times. Due to the modular design different element types can be installed into the housing, resulting in a highly flexible filtration system.

The P-EG housing is designed and developed for the following applications:

Filtration of air and gases

- Compressed Air
- Carbon Dioxide
- Technical Gases

Filtration of Steam

DIRECTIVES

All P-EG housings are designed in accordance with

- FDA CFR Code of Federal Regulations Title 21
- Pressure Equipment Directive 97/23/EC
- Framework regulation 1935/2004/EC



PRODUCT SPECIFICATIONS

Product Specifications

Inner Surface Finish:	<ul style="list-style-type: none"> • 0006-0288: etched and passivated Ra 1,6* • 0432-1920: etched and passivated Ra 1,6*
Outer Surface Finish:	<ul style="list-style-type: none"> • 0006-0288: etched, passivated and polished Ra 1,6* • 0432-1920: etched and passivated Ra 1,6*
Maximum Operating Pressure:	<ul style="list-style-type: none"> • 0006-0192: 16 bar • 0288: 12 bar • 0432-1920: 10 bar
Maximum operating temperature:	<ul style="list-style-type: none"> • -25 / +150°C
Connection types:	<ul style="list-style-type: none"> • BSP thread connection (Standard for 0006-0288 single housings) • DIN flange (standard starting at 0432 multiple housing) • Welded ends

*Ra-values don't apply to welding seams

HOUSING TYPE P-EG 0006-0288 WITH THREAD CONNECTION

Pos.	Piece	Description
6	2	plug 1/4"
5	1	filter element
4	1	nut
3	1	housing gasket
2	1	lower housing bowl
1	1	upper housing bowl

Max. Operating Pressure:	
0006-0192:	16 bar
0288:	12 bar
Test pressure:	
	<u>1.4301</u> <u>1.4404</u>
0006-0192	29.3 bar 27.0 bar
0288:	22.0 bar 20.2 bar
Max. Operating Temperature: -25 / +150°C	
Material Housing: 1.4301 or 1.4404/1.4435	
Attaching Parts: 1.4301	
Surface Finish:	
inside R _a 1,6*; etched and passivated	
outside R _a 1,6*; etched, passivated and polished	

*Ra-values don't apply to welding seams

Classification acc. To 97/23/EG for fluids group 2	
P-EG 0006-0048	Art. 3, par. 3
P-EG 0072-0288	Cat. I

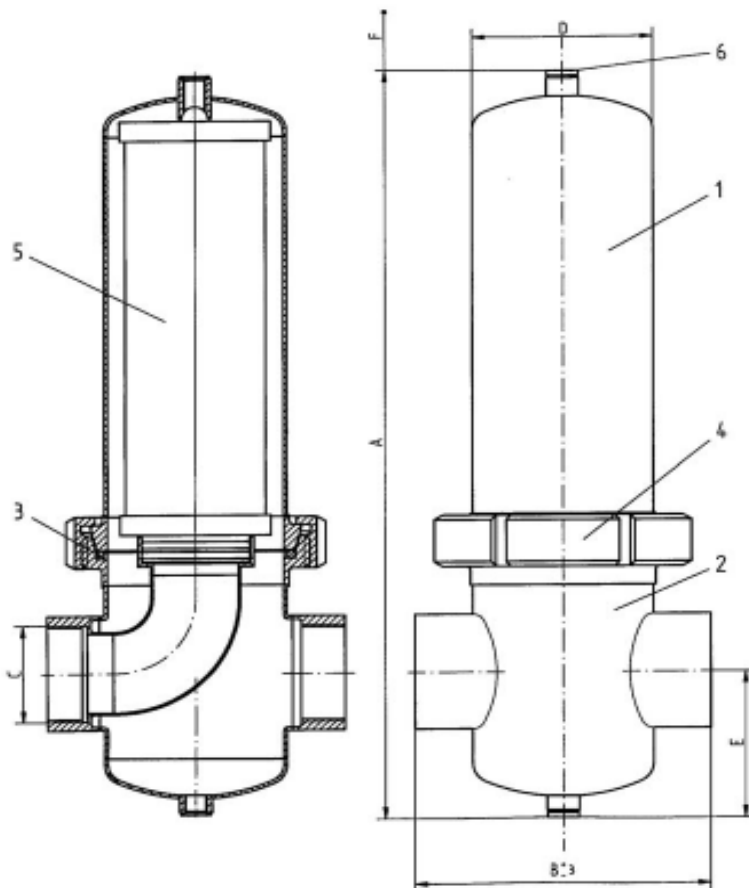

Size	Volume (l)	Weight (kg)	A mm	B mm	C	ØD mm	E mm	F mm	Element
0006	0,55	1,7	215	108	G 1/4	70	55	90	03/10
0009	0,65	1,9	245	108	G 3/8	70	55	120	04/10
0012	0,65	1,9	245	108	G 1/2	70	55	120	04/20
0018	0,75	2,0	270	125	G 3/4	70	55	150	05/20
0027	1,0	2,6	295	125	G 1	85	75	150	05/25
0036	1,25	3,0	345	140	G 1 1/4	85	75	200	07/25
0048	2,3	4,3	390	170	G 1 1/2	104	100	200	07/30
0072	3,3	4,8	465	170	G 2	104	100	280	10/30
0108	4,3	5,3	590	170	G 2	104	100	450	15/30
0144	8,0	9,0	735	216	G 2 1/2	129	110	580	20/30
0192	11,1	10,8	1000	216	G 3	129	110	850	30/30
0288	16,5	16,2	1025	240	G 3	154	120	850	30/50

HOUSING TYPE P-EG 0006-0288 WITH WELDED ENDS FOR ISO- PIPE

Pos.	Piece	Description
6	2	plug 1/4"
5	1	filter element
4	1	nut
3	1	housing gasket
2	1	lower housing bowl
1	1	upper housing bowl

Max. Operating Pressure:	
0006-0192:	16 bar
0288:	12 bar
Test pressure:	
	<u>1.4301</u> <u>1.4404</u>
0006-0192	29.3 bar 27.0 bar
0288:	22.0 bar 20.2 bar
Max. operating temperature: -25 / +150°C	
Material housing: 1.4301 or 1.4404/1.4435	
Attaching parts: 1.4301	
Surface finish:	
inside R _a 1,6*; etched and passivated	
outside R _a 1,6*; etched, passivated and polished	

*Ra-values don't apply to welding seams

Classification acc. To 97/23/EG for fluids group 2	
P-EG 0006-0048	Art. 3, par. 3
P-EG 0072-0288	Cat. I

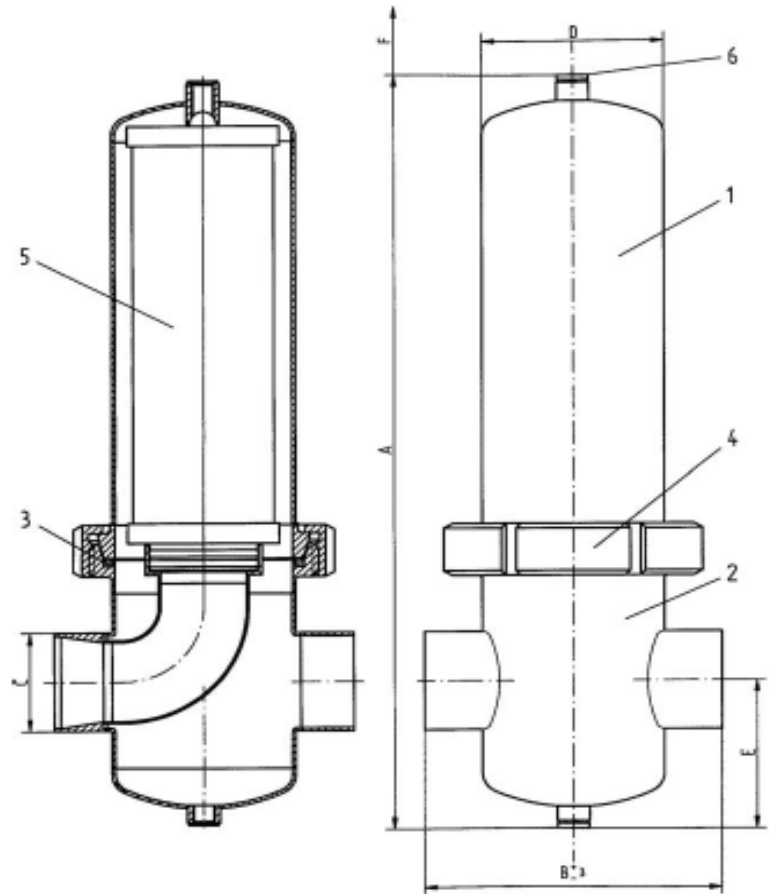

Size	Volume (l)	Weight (kg)	A mm	B mm	C	ØD mm	E mm	F mm	Element
0006	0,55	1,7	215	108	17,2/DN 10	70	55	90	03/10
0009	0,65	1,9	245	108	17,2/DN 10	70	55	120	04/10
0012	0,65	1,9	245	108	21,3/DN15	70	55	120	04/20
0018	0,75	2,0	270	125	26,9/DN 20	70	55	150	05/20
0027	1,0	2,6	295	135	33,7/DN 25	85	75	150	05/25
0036	1,25	3,0	345	140	42,4/DN 32	85	75	200	07/25
0048	2,3	4,3	390	170	48,3/DN 40	104	100	200	07/30
0072	3,3	4,8	465	170	60,3/DN 50	104	100	280	10/30
0108	4,3	5,3	590	170	60,3/DN 50	104	100	450	15/30
0144	8,0	9,0	735	200	76,1/DN 65	129	110	580	20/30
0192	11,1	10,8	1000	200	88,9/DN 80	129	110	850	30/30
0288	16,5	16,2	1025	240	88,9/DN 80	154	120	850	30/50

HOUSING TYPE P-EG 0006-0288 WITH FLANGE CONNECTION

Pos.	Piece	Description
6	2	plug 1/4"
5	1	filter element
4	1	nut
3	1	housing gasket
2	1	lower housing bowl
1	1	upper housing bowl

Max. Operating Pressure:	
0006-0192:	16 bar
0288:	12 bar
Test Pressure:	
	<u>1.4301</u> <u>1.4404</u>
0006-0192	29.3 bar 27.0 bar
0288:	22.0 bar 20.2 bar
Max. Operating temperature: -25 / +150°C	
Material Housing: 1.4301 or 1.4404/1.4435	
Attaching Parts: 1.4301	
Surface Finish:	
inside R _a 1,6*; etched and passivated	
outside R _a 1,6*; etched, passivated and polished	

*Ra-values don't apply to welding seams

Classification acc. To 97/23/EG for fluids group 2	
P-EG 0006-0048	Art. 3, par. 3
P-EG 0072-0288	Cat. I

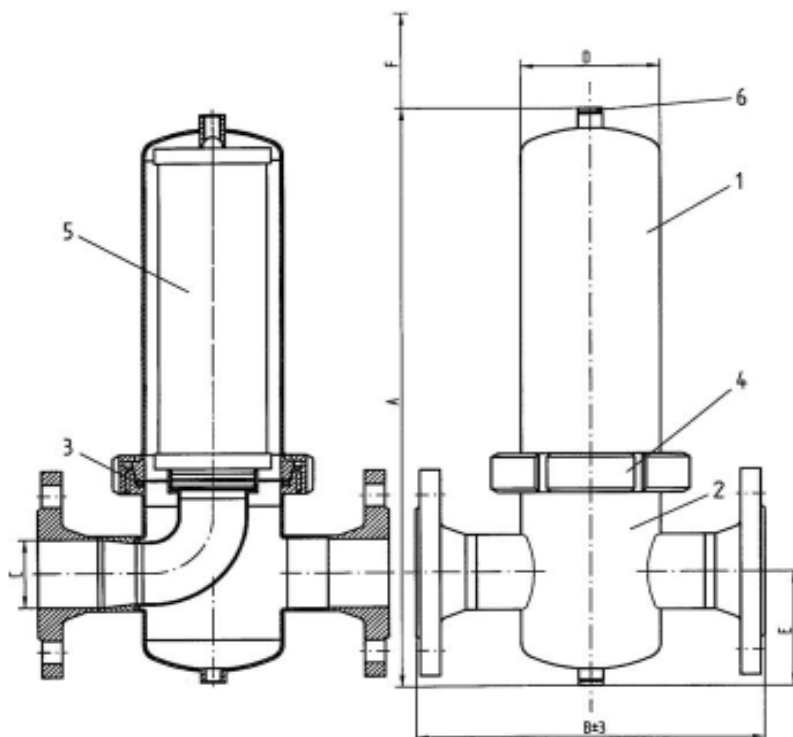

Size	Volume (l)	Weight (kg)	A mm	B mm	C	ØD mm	E mm	F mm	Element
0006	0,55	2,7	215	180	DN 10	70	55	90	03/10
0009	0,65	2,9	245	180	DN 10	70	55	120	04/10
0012	0,65	3,4	245	180	DN15	70	55	120	04/20
0018	0,75	4,0	270	202	DN 20	70	55	150	05/20
0027	1,0	4,8	295	212	DN 25	85	75	150	05/25
0036	1,25	6,4	345	220	DN 32	85	75	200	07/25
0048	2,3	8,0	390	254	DN 40	104	100	200	07/30
0072	3,3	10,0	465	260	DN 50	104	100	280	10/30
0108	4,3	10,5	590	260	DN 50	104	100	450	15/30
0144	8,0	15,0	735	290	DN 65	129	110	580	20/30
0192	11,1	18,2	1000	300	DN 80	129	110	850	30/30
0288	16,5	23,6	1025	340	DN 80	154	120	850	30/50

HOUSING TYPE P-EG 0432-19220 WITH FLANGE CONNECTION

Pos.	Description
13	spring
12	lifting eye bolt
11	plug
10	filter element
9	anchor bolt
8	bracket plate
7	bracket bolt
6	gasket
5	nut
4	washer
3	hexagon bolt
2	lower housing bowl
1	upper housing bowl

Max. Operating Pressure:	10 bar
Test Pressure:	18.3 bar
Max. Operating Temperature:	-25 / +150°C
Material Housing:	1.4301
Attaching Parts:	1.4301
Surface Finish:	etched and passivated

Classification acc. to 97/23/EG for fluids group 2	
P-EG 0432-0768	Cat. II
P-EG 1152-1920	Cat. III

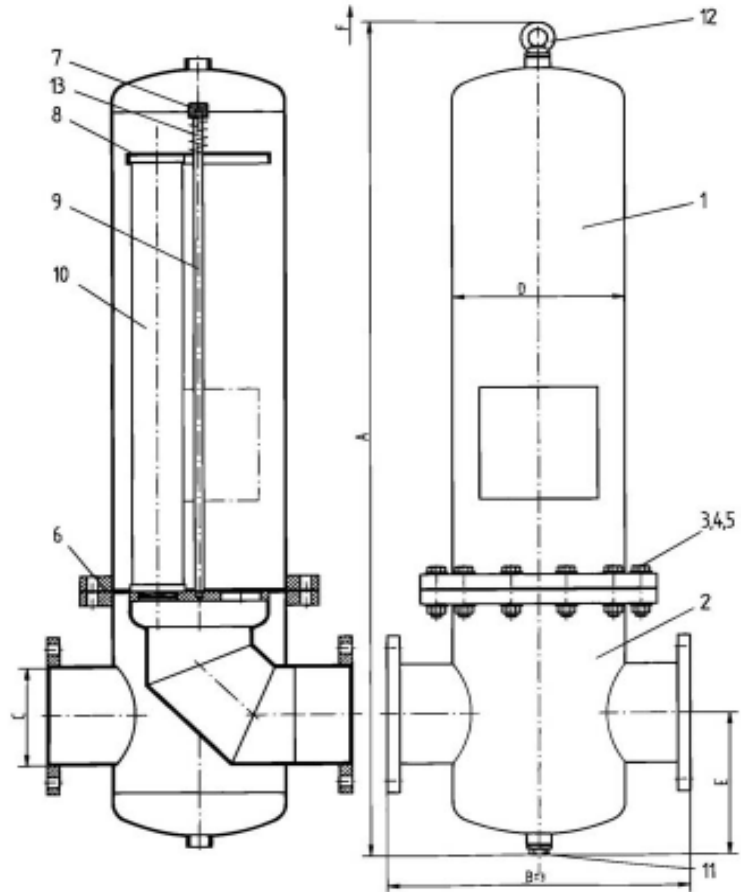

Size	Volume (l)	Weight (kg)	A mm	B mm	C	ØD mm	E mm	F mm	Element
0432	36	43	1090	410	DN 100	219.1	200	580	3x 20/30
0576	54	44	1350	410	DN 100	219.1	200	850	3x 30/30
0768	77	70	1410	480	DN 150	273	240	850	4x 30/30
1152	110	80	1460	540	DN 150	323.9	250	850	6x 30/30
1536	190	135	1600	660	DN 200	406.4	300	850	8x 30/30
1920	190	135	1600	660	DN 200	406.4	300	850	10x 30/30

Technical alterations reserved 04/2009

- For information on test equipment or test services, please contact your Donaldson Sales Engineer and visit our website at www.donaldson.com!

(Rev07 - 11/13)

