

Ultrapure ALG 35 S - 375 S

Breathing Air System with adsorption dryer, CO and CO₂ – NO_x – and SO₂ precipitation, pre- and afterfilters and automatic condensate drain.



The Ultrapure breathing air systems are desiccant dryer type purification systems to supply breathing air in compliance with all relevant international standards and medical prescriptions.

This is guaranteed by a multistage purification:

At the inlet (J) compressed air reaches a two stages filter combination (6,7). In this stage the air is separated from particles and condensate.

The condensate is drained off the system via the electronic condensate drain (12).

The following desiccant dryer reduces the water vapour content of the compressed air down to a pressure dew point of –40 °C (equivalent to a remaining water content of 0,11 g/m³). In the following processing stages (SP, AK, OX) the CO₂ of below 500 ppm of the content the content of SO₂ is reduced to a level below 1 ppm and the content of NO_x below 2 ppm.

In addition to that oil vapour, hydrocarbon, tastes and odours are held back in the AKstage up to a residual content below 0,003 mg/m³. In the OX-stage the existing CO is transformed into CO₂ through a catalytic reaction. In this way the CO content is reduced to < 5 ppm.

In the after filter (dust filter) possible abrasion of the absorber is removed.

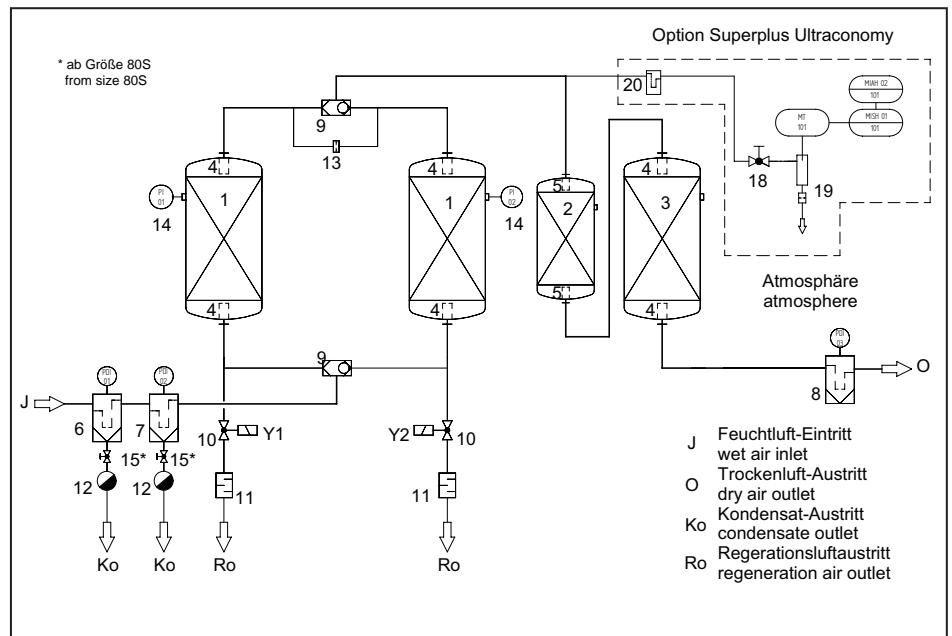

ALG	Nominal flow Inlet m ³ /h (1 bar, 20°C)*	Reg. Air flow average m ³ /h (1 bar, 20°C)	Air outlet (min) m ³ /h (1 bar, 20°C)	Loss of heat new mbar	Prefilter (afterfilter) M, S (M)
35 S	35	5.3	28.5	160	0070
80 S	80	12	65.2	170	0210
100 S	100	15	81.6	200	0210
150 S	150	23	121.7	300	0210
225 S	225	34	183.2	200	0450
300 S	300	45	244.7	250	0450
375 S	375	56	306.1	320	0450

* Related to 1 bar (abs) and 20 °C at intake of compressor and 7 bar (g) and 35 °C inlet temperature

Ultrapure ALG 35 S - 375 S

Features:	Benefits:
Breathing air package incl. absorption dryer, CO, CO ₂ -, NO _x and SO ₂ precipitation, pre- and after filter and automatic level-controlled condensate drain	Turnkey system, no additional installation required, all components from one hand, technically perfectly matched to each other
Guaranteed and validated separation efficiency	Breathing air quality in compliance with all relevant international standards, e.g. Pharmacopée Européenne; DIN EN 12021; DIN EN ISO 7396-1; BS4275; ANSI/CGA G.7.1; Z180, 1 M85; AS2299-1979; NZL5813
All dryers are in cabinet construction	Optimum protection against mechanical damage and against dirt
Display of the operating status by LED	High operating safety, since all operating status can be detected easily at any time
Intermittend operation standard	Link between dryer and compressor possible on central applications, therefore saving of compressed air
Optimal adaptation and generous dimensioning of the components	Long lean-times of the processing stages, low differential pressure of the plant; result: low operation costs

Residual content at standard entrance conditions	
Particles	Class 2, ISO 8573-1:2001
Oil (fluid phase)	< 0,01 mg/m ³
Oil vapour and hydrocarbon	< 0,003 mg/m ³
Water vapour	DTP -40°C (= 0,11 g/m ³)
CO ₂	< 500 ppm
CO	< 5 ppm
SO ₂	< 1 ppm
NO _x	< 2 ppm
Tastes and odours	free of tastes and odours

Sizing:													
Operating pressure bar (g)	4	5	6	7	8	9	10	11	12	13	14	15	16
Correction value Overpressure fp)	0.63	0.75	0.88	1.0	1.12	1.25	1.38	1.50	1.63	1.75	1.88	2.0	2.13
Entrance temperature °C	20	25	30	35	40	45	50						
Correction value Temperature (f _T)	1.1	1.1	1.1	1.0	0.8	0.7	0.5						
<p>Example: $\dot{V}_{nom} = 50 \text{ m}^3/\text{h}$, Inlet temperature = 30°C, Operating pressure = 10 bar (g),</p> $\dot{V}_{corr} = \frac{\dot{V}_{nom}}{f_p \cdot f_T}$ $\dot{V}_{corr} = \frac{50 \text{ m}^3/\text{h}}{1,38 \cdot 1,1} = 32,94 \text{ m}^3/\text{h}. \text{ Calculated dryer size: ALG 35 S}$													

Product description:
Ultrapure ALG-S Complete processing system for breathing air, incl. adsorption dryer, CO ₂ -, NO _x - and SO ₂ precipitation, pre-and afterfilter and automatic level controlled condensate drain

Medium:
Compressed air

Operation pressure:
min. 4 bar (g), max. 16 bar (g)

Medium temperature:
max. +50 °C

Ambient temperature:
min. +4 °C, max. +50 °C

Power Supply:
230 V/ 115 V AC/ 50 – 60 Hz, 24 V DC

Power consumption:
approx. 40 W

Pressure vessel – design, manufacture, testing:
Absorber: acc. to 87/404/EEC Filter: acc. to 97/23/EC

Declaration of conformity:
Type 35 S – 150 S: acc. to 2006/95/EC
Type 225 S – 375 S: acc. to 97/23/EC

Ultrapure ALG 35 S - 375 S

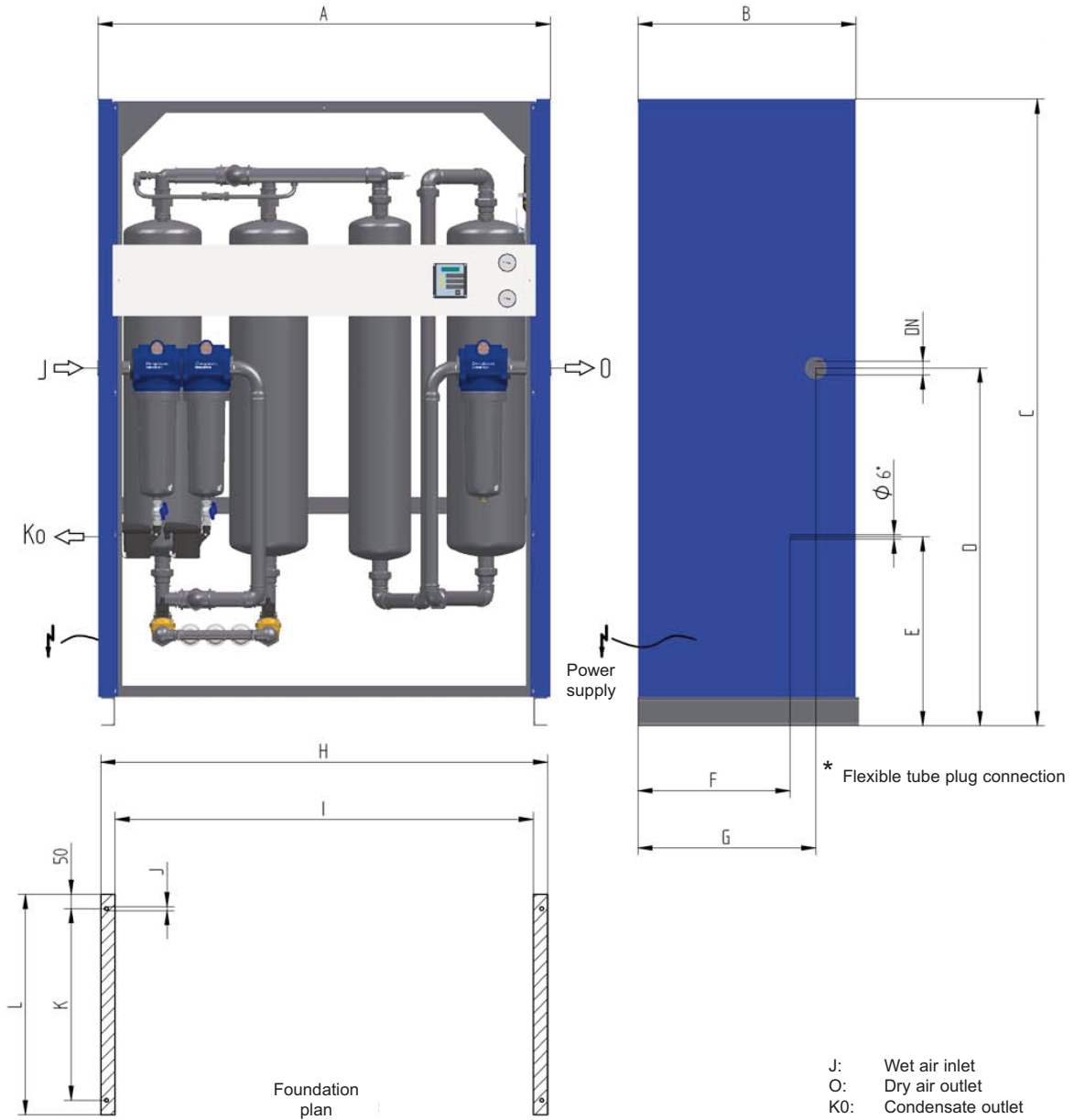

Type	DN "	A mm	B mm	C mm	D mm	E mm	F mm	G mm	H mm	I mm	J mm	K mm	L mm	Weight kg
35 S	G 1/2	650	340	1060	700	310	255	255	640	620	6,5	215	315	70
80 S	G 3/4	940	460	1610	800	415	315	340	920	880	13	360	460	199
100 S	G 1	940	460	1610	800	415	315	340	920	880	13	360	460	240
150 S	G 1	1140	680	1980	1075	535	465	535	1120	1080	13	580	680	288
225 S	G 1 1/2	1140	680	1980	1075	535	465	535	1120	1080	13	580	680	420
300 S	G 1 1/2	1580	770	2190	1250	660	530	620	1560	1520	13	670	770	530
375 S	G 1 1/2	1580	770	2190	1250	660	530	620	1560	1520	13	670	770	795